

# pulse

The ElringKlinger AG Magazine  
Issue 2024



## TRIPLE

What does the new Management Board team stand for and how does it see the future of ElringKlinger?

## THE BIG PICTURE

As a full-service supplier, we always look at the big picture and play an active role in the process of transformation towards e-mobility and sustainability.

## CHAIN REACTION

How the transformation of the automotive industry is changing the supply chain – and how ElringKlinger is helping to shape this change.

# ElringKlinger – BRIEF & COMPACT

As an automotive supplier, ElringKlinger develops high-tech solutions for all types of drive system, the aim being to actively shape the present and future era of sustainable mobility.

EUR **1,847** MILLION

was the total revenue generated by ElringKlinger in the 2023 financial year.

**5.2%**

of Group revenue was spent on research and development in the year under review.

**9,576**

#transformationpioneers, around the globe, were employed by ElringKlinger as of December 31, 2023.

**# ElringKlinger**

Follow ElringKlinger on the social media networks of Facebook, Instagram, LinkedIn, Xing and YouTube or get more information on our website [www.elringklinger.com](http://www.elringklinger.com)

## Dear Readers,



Thomas Jessulat,  
CEO of ElringKlinger AG

we are in the midst of transformation, particularly when it comes to the automotive industry. The changes are truly profound.

SHAPE30 is the formula for success when it comes to driving forward ElringKlinger's transformation. For us on the Management Board, making the Group fit for the future is of key importance. We are building on strong foundations, focusing on our customers' needs and drawing on our core competencies as the basis for next-generation products. The process of transformation is being driven by the key factors that underpin our success. Our long-standing business forms a solid backbone for this transition.

In recent months, we have secured large-scale nominations for products in the field of new drive technologies, and projects within this area are currently underway. Building on this strong base of orders centered around the mobility of the future, ElringKlinger has charted its course for transformation. We shall succeed in our endeavors.

At ElringKlinger, the transformation of mobility has long been underway. Find out for yourself!



# 14

## Triple

ElringKlinger is led by a new Management Board team. What does the new team stand for and how does it see the future of ElringKlinger? Immerse yourself in what could be seen as a typical working day for the Management Board and discover the trio's dynamic and highly focused style.



# 20

## Components of the Future

Series production of cell contacting systems commenced at the Neuffen site in 2023. These operations are now undergoing major expansion. The e-mobility site plays a pivotal role in the Group strategy adopted by ElringKlinger.

## Compassion with Conviction

At ElringKlinger, a progressive corporate culture goes hand in hand with a culture of responsible leadership. Throughout his life, founder Paul Lechler lent his support to various projects and embraced social responsibility. Today, managers are following the example of the company's founder: we present three social projects by up-and-coming young professionals at ElringKlinger who show true compassion and conviction in their efforts to make a lasting difference.

44



26



## Green Steam ahead

Fuel cell stacks can be used in a variety of ways – not only in those areas in which power is needed but also in the production of hydrogen as an energy source. We present stacks developed by EKPO, the fuel cell specialist within the ElringKlinger Group, and highlight three new orders secured during the financial year 2023 that represent our achievements and our latest endeavors.

## CONTENTS

- 06 #transformationpioneers
- 14 Triple
- 20 Components of the Future
- 26 Green Steam ahead
- 30 The Big Picture
- 36 That's the Spirit
- 40 Chain Reaction
- 44 Compassion with Conviction
- 48 Global Presence

» FROM DEVELOPMENT AND PROTOTYPING TO TESTING AND SERIES PRODUCTION, AT ELRINGKLINGER EVERYTHING IS BASED ON IN-HOUSE EXCELLENCE. THANKS TO OUR PROWESS IN INNOVATION, AMONG OTHER FACTORS, OUR TRACK RECORD AS A SERIES SUPPLIER IN THE FIELD OF BATTERY TECHNOLOGY NOW SPANS MORE THAN A DECADE. «

# INNOVATION

Dependability, creativity, and a commitment to exceptional quality – ElringKlinger is a valued partner in the field of electromobility. The Center of Excellence in Neuffen is the beating heart of battery technology.

▶ [READ MORE ON P. 20](#)









» TOGETHER, WE TACKLE CHALLENGES AND DEVELOP THE RIGHT SOLUTIONS. EMBRACING THE SPIRIT OF A TEAM GAME, WE ENCOURAGE EVERY MEMBER TO CONTRIBUTE FROM THEIR OWN PERSPECTIVE. «

# TEAM SPIRIT

From a supplier of products used in vehicles powered by combustion engines to a specialist in components and systems for sustainable mobility – that is our chosen path of transformation. Evolving ElringKlinger's corporate culture is one of five success factors guiding us in our endeavors. We are committed to driving it forward as a team.

➤ FIND OUT MORE ON P. 36

» PRODUCTS, INNOVATIONS, CUSTOMERS – THESE ARE THE FOCAL POINTS OF OUR DAILY EFFORTS. THE TRANSFORMATION OF OUR PRODUCT PORTFOLIO IS ALREADY WELL UNDERWAY. WHAT IS MORE, WE ARE RELENTLESS IN OUR PURSUIT OF FURTHER INNOVATIONS IN OUR STRATEGIC FIELDS OF THE FUTURE. «

# FOCUS

Whether classic combustion engine or e-mobility, ElringKlinger can leverage its core competencies in all drive technologies. Building on our established business as a solid backbone, we are driving forward the transformation of the Group.

➤ [READ MORE ON P. 30](#)



EKPO FUEL CELL TECHNOLOGIES



EKPO FUEL CELL TECHNOLOGIES  
Type: EKPO-FC-100-100  
Capacity: 100 kW  
Operating pressure: 10 bar  
Manufacturing year: 2024, 2025

EKPO

V2

V2

» SUSTAINABLE MANAGEMENT IS AN ESSENTIAL PREREQUISITE FOR TREATING OUR PLANET IN A WAY THAT IS FAIR TO ALL GENERATIONS. IT IS WITH THIS IN MIND THAT WE MEET ECOLOGICAL, SOCIAL, AND ECONOMIC CHALLENGES BY DRAWING ON RESOURCES THAT ARE INEXHAUSTIBLE: PASSION, THE POWER OF INNOVATION, AND A CULTURE DRIVEN BY PRACTICED VALUES. «

# SUS TAIN ABIL ITY

Hydrogen-based mobility is gathering pace in the world's largest vehicle market. EKPO has already laid the necessary foundations in China, the aim being to further develop the fuel cell market there. The spectrum of future applications for hydrogen-based technologies is broad.

» FIND OUT MORE ON P. 26





**As from 2023, ElringKlinger is led by a new Management Board team: Thomas Jessulat (CEO), Reiner Drews (COO), and Dirk Willers (CSO). What does the new team stand for and how do they see the future of ElringKlinger? Immerse yourself in what could be seen as a typical working day for the Management Board and discover the trio's dynamic and highly focused style.**

# TRIPLE

It is early in the morning as Thomas Jessulat kicks off his working day. Before heading to the car for the commute to the office, he checks the e-mails that have poured in overnight. Some are answered directly, then he makes a mental note of the list of people he needs to contact on his way to the office. Having completed the phone calls, he listens to a podcast briefing on the day's key news items.

The very first meeting of the CEO's day at the office is with the Battery Technology & Electric Drive business unit. Thomas Jessulat gets together with the head of this unit to discuss the strategic direction to be taken. This is a key issue, as it is in this area that the Group's transformation will manifest itself in the form of revenue growth over the next few years. Production ramp-up for an order placed by a global battery manufacturer, covering a total volume in the mid triple-digit million euro range, is currently underway. In addition, the company managed to secure a high-volume order from the BMW Group for its "Neue Klasse" series ("New Class") in 2023. Alongside the large-scale series nominations for components, the business unit has also received orders for other products, such as battery systems, production of which is scheduled to commence in the next few years. What applies to battery technology is also true for fuel cell technol-

ogy: the joint venture subsidiary EKPO Fuel Cell Technologies is in the midst of ramp-up for a large series production order for bipolar plates in the second half of the decade. Preparations for this project are already underway.

As Thomas Jessulat points out, success during the ramp-up stage is of crucial importance to ElringKlinger: "ElringKlinger is in the midst of the mobility transformation and, thanks to its technological focus, it is ideally equipped for the task, as evidenced by the numerous nominations for e-mobility applications received in the last twelve months." The emphasis now, as he explains, is on implementing this at an operational level. Revenue is set to expand gradually as the larger orders ramp up, and it is essential that growth is structured in a manner that is profitable. "That is our mission and we are fully committed to it," as the Management Board is always keen to point out.

\*\*\*

Reiner Drews meets with the managers of his area of responsibility in an effort to drive forward global floorspace planning for the future. This is considered a major task for ElringKlinger, given

the fact that the company is faced with a downturn in demand in its traditional area of business, while also having received high-volume nominations for which it now has to conceive and execute a suitable ramp-up roadmap. "The transformation seen within our industry is leading to changes that we have to embrace and manage accordingly," says Drews.

The future of the long-standing business units is a key item on the agenda at a meeting with the managers of these units. The issue of transformation is of relevance not only to the E-Mobility business unit with its fuel cell technology, battery technology, and electric drive units but also to the "traditional" areas of business. "From a strategic perspective, these business units have also been geared up to develop and market innovative solutions centered around new drive technologies," says Drews. With success. The area of business formerly dedicated to shielding technology received letters of nomination for battery housings and battery housing components in 2023. The unit originally specializing in seals and gaskets recently chalked up sales successes relating to rotor-stator laminated stacks. And in the area of lightweighting, mass-produced structural components and metal-elastomer seals/gaskets for purely electric vehicles have been rolling off the production line for some time now. "These business units are transforming themselves from within, so to speak, drawing on their inherent skills and expertise," says Drews.

\*\*\*

Dirk Willers is on his way back to Dettingen/Erms in the morning. The evening before, he had attended a customer event hosted by a major European manufacturer and, accompanied by the sales team of the unit in question, accepted an award on behalf of ElringKlinger as Best Supplier in 2023. "An award like this is of central importance to us in sales," says Willers in summarizing the significance of this latest accolade. "We see it as a direct form of customer feedback. Customer satisfaction is the greatest possible endorsement for us. At the same time, we also regard it as an incentive to become even better." It is similar to sporting endeavors: coming first is a real challenge. Staying first, on the other hand, is even more difficult.

ElringKlinger's goal is to be at the very top. This point was highlighted most recently as part of an internal review of the Group's value system. ElringKlinger is a technology-driven company, as a result of which innovation is of central importance. The hive of activity seen throughout the company's research and develop-

**» The objective for the coming years is to consistently translate these credentials into sustainable success. We have charted a clearly defined course to achieve this. «**

Thomas Jessulat, CEO of ElringKlinger AG

**» ElringKlinger is in the midst of the mobility transformation and, thanks to its technological focus, it is ideally equipped for the task, as evidenced by the numerous nominations for e-mobility applications received in the last twelve months. «**

Thomas Jessulat, CEO of ElringKlinger AG

ment departments is a testament to this, as are the sheer number and quality of patents filed.

"Innovation is one thing," as Willers points out. "But focus is the other key element for us." This focus, as he explains, includes placing the customer and their needs at the center of attention. This is also reflected in the Group's vision. ElringKlinger endeavors to be a preferred partner when it comes to advancing innovative technologies. As Willers explains, it is this ambition that provides the basis for the Group's new sales strategy: "As part of a concerted effort, we want to explore new horizons by developing innovations while remaining firmly focused on ElringKlinger's strategy, the aim being not only to tap into the market but also to turn our vision into reality."

\*\*\*

By now it's midday. All three Management Board members have already attended several meetings at the Group headquarters in Dettingen/Erms. Reiner Drews took part in a video call with the Asian plant managers for an operational status report on the sites in the Asia-Pacific region – a morning slot because of the time differences. Meetings such as these tend to revolve around issues such as capacity levels and capacity utilization as well as the resilience of supply chains. "Robustness, reliability, and continuous improvement are at the forefront of our production processes worldwide," he emphasizes. "This is at the heart of our ElringKlinger Operating System."

Dirk Willers' meeting with team members from the Aftermarket business unit is centered around the strategic direction to be taken by the segment. Prior to his appointment to the Management Board in 2023, he was responsible for the Aftermarket business and achieved lasting success in terms of both revenue and profitability. "A team effort," as Willers always emphasizes. The segment now forms part of his Management Board remit – as does the Engineered Plastics segment, which has a proven track record in various sectors as a supplier of high-performance plastics.

Thomas Jessulat's schedule for the morning has included appointments with staff members as well as external points of contact. The company's principal bank, for example, is among the partners he converses with on a regular basis. Others include representatives of the Global Strategy corporate unit, with whom he discusses the product group strategy in further detail. This is followed by a video call with the German Association of the Automotive Industry (VDA).



**Thomas Jessulat,  
born in 1969, CEO,**

is responsible for managing the Group, drawing on his extensive financial expertise and a broad technical background. Having graduated from TU Braunschweig as a mechanical engineer, he embarked on a career at Daimler-Benz Aerospace AG, Ulm, in 1995. Three years later, he moved to the United States, where he worked for the same company and also completed an MBA in Finance at the University of Cincinnati. After a spell at Fairchild Dornier GmbH in Munich, he joined ElringKlinger AG in 2005 and took on various management roles within the finance department in the years that followed. He was appointed CFO in January 2016 and assumed the position of CEO in October 2023. Under his guidance, the Battery Technology business unit has recently secured numerous series production nominations and is set for strong growth in the future.



**5 Success factors**

*Product transformation*

**#1**

In developing high-performance products for e-mobility applications, we are looking to seize the opportunities presented by the current transformation. Our strong market position in the long-standing areas of business forms the backbone for these endeavors.

*Sustainability*

**#2**

We are taking present-day action in support of our responsibility to future generations – in ecological, social, ethical, and economic terms.

*Process & performance excellence*

**#3**

We record all processes, assess them with regard to their progress, maturity, and success on the basis of given metrics, and optimize them accordingly.

*Digital transformation*

**#4**

With a view to embracing the new level of digitalization, we are committed to the effective alignment of our processes, which also includes the aspect of time and resource efficiency.

*Corporate culture*

**#5**

In pursuit of successful transformation, we are looking to evolve on the basis of a modern corporate culture that is receptive to change but at the same time target- and values-driven.

**2030**

His to-do list also includes a meeting with the HR department to discuss the results of a recent employee survey and to determine the next steps. Feedback from the global workforce is essential for the Management Board team when it comes to refining and evolving the fundamental structures of a corporate culture geared toward long-term success.

\*\*\*

Today, the Management Board meeting takes place in a room on the fourth floor of the admin building. The meeting room offers a perfect vista of the entire site. EKPO Fuel Cell Technologies is also based at this location.

The key agenda item for this Management Board meeting is centered around an in-depth review of ElringKlinger's strategy for successful transformation. SHAPE30 describes the strategic roadmap for the further course of the decade and encompasses five success factors that ElringKlinger will use to shape the future of the Group. It is within these areas that ElringKlinger is looking to build on its capabilities and play to these strengths in pursuit of success.

The first step is product transformation. Drawing on its core competencies, the company was quick off the mark in its efforts to develop products tailored to next-generation mobility. A prime example: ElringKlinger's track record as a series supplier of battery components spans more than a decade. The so-called cell contacting system, which was the first of its emerging technologies to make the leap into series production, has since established itself as one of the Group's core products. The high-volume orders from

a global battery manufacturer and the BMW Group are complemented by additional nominations in the other business units. In fact, the company's order books are brimming thanks to all the series production nominations. For Thomas Jessulat, this is a key to ElringKlinger's future performance: "The objective for the coming years is to consistently translate these credentials into sustainable success. We have charted a clearly defined course to achieve this."

This plan includes sustainability as a further success factor. At the heart of this concept are the essential elements that drive environmentally friendly practices throughout the company's own manufacturing operations and along the entire value chain. Added to this are social and ethical aspects in the form of sound corporate governance based on statutory provisions and moral principles.

**» In order to successfully shape the process of transformation, we will continue to focus on raising efficiency levels and achieving lasting growth in the future. «**

Reiner Drews, COO of ElringKlinger AG



**Reiner Drews**  
born in 1969, COO,

has always had a strong focus on production. After training as a toolmaker, he completed a degree in production engineering and went on to gain an MBA in International Marketing at the European School of Business in Reutlingen. After entering the job market in 1995, he held positions as plant manager, technical manager, and head of production at several medium-sized enterprises. In September 2006, he assumed responsibility for what was then the Specialty Gaskets division at ElringKlinger, and later also the Cylinder-head Gaskets division. In his role as Chief Operating Officer, a position he has held since April 2018, he has implemented a new operating system at ElringKlinger that maps, structures, and optimizes the Group's processes.



**Dirk Willers,  
born in 1973, CSO,**

studied business administration, majoring in marketing and finance, at the University of Bayreuth and the University of Nebraska in Lincoln, USA. Having embarked on his career with management consultants Booz Allen Hamilton in Chicago, USA, he moved to what was then DaimlerChrysler AG in 2003, where he held various senior positions in sales. In 2015, he assumed responsibility for Aftermarket business at ElringKlinger AG, which he led to strong and profitable growth on the basis of a new strategy. In October 2023, he was appointed to the Management Board as Chief Sales Officer. Operating in line with a new sales strategy, ElringKlinger is determined to step up its market and marketing activities for the Group's wide-ranging product portfolio – both in the field of mobility and beyond, e.g., in hydrogen generation.

**» As part of a concerted effort, we want to explore new horizons by developing innovations while remaining firmly focused on ElringKlinger's strategy, the aim being not only to tap into the market but also to turn our vision into reality. «**

Dirk Willers, CSO of ElringKlinger AG

Digital transformation with the long-term objective of creating a digital factory as well as the aspect of process and performance excellence also form an integral part of SHAPE30. The focus here is on optimizing processes and leveraging values that benefit ElringKlinger, its customers, and all stakeholders. Reiner Drews puts it this way: "In order to successfully shape the process of transformation, we will continue to focus on raising efficiency levels and achieving lasting growth in the future."

For all three members of the Management Board team, evolving ElringKlinger's corporate culture is one of the essential prerequisites for success on the path to transformation. The parameters must be such that they provide scope for empowerment and foster innovation. In this context, trust, passion, team spirit, integrity, sustainability, innovation, and a focus on strategic priorities are to be seen as an important foundation.

Having discussed and agreed the details of the strategy blueprint, the three Management Board members briefly address other essential issues. Among the focal points are the aspect of future market development, the pipeline of nominations, and assessment reports submitted by the sales team. They also discuss the degree of target attainment with regard to the key performance indicator system and outline the essential parameters relating to strategic measures that are designed to provide impetus for the future within the Group.

Having completed these tasks, the three of them turn their attention to other business matters over the course of the afternoon. And suddenly it's evening. CEO Thomas Jessulat's final appointment slot – as the day draws to a close – is taken up by the Communications department. "Agreed" – he approves a document and ends the call. Having parked his electric vehicle in its usual place, he is finally back home.

# COMPONENTS OF THE



The transformation of the automotive industry is advancing at pace. In this setting, it is self-evident that battery technology has a key role to play. Indeed, if the transition to low-emission or even emission-free mobility is to succeed, registrations of battery electric vehicles will have to pick up speed rapidly. In 2022, ElringKlinger chose Neuffen as the location for its battery business – and is now in the process of expanding its overall capacity just a few years after the facility was inaugurated. The e-mobility site plays a pivotal role in the Group’s strategy.





# FUTURE

# 4,500 m<sup>2</sup>

the space to be added to the Neuffen site as part of its planned expansion.

Jürgen Weingärtner, Senior Vice President Electric Drive and Battery Technology, is brimming with energy. Plans to expand the Neuffen site are in full swing, and the first steps have already been taken. The sheer scale of the project becomes abundantly clear when one looks at the floor plan attached to the flipchart in front of him. The current production space of 14,500 square meters is to be expanded by a further 4,500 square meters. This was prompted by the volume of incoming orders for e-mobility applications. Since 2021, these have added up to around 2.5 billion euros, according to Weingärtner's calculations. The majority of these are being processed in Neuffen.

The location of the site for emerging technologies is perfect. Just 10 kilometers from the Group headquarters in Dettingen/Erms, cell contacting systems are manufactured on a production line in two shifts – three years after the facility commenced operations. Every week, a large-scale consignment leaves the plant and makes its way to the customer, a global battery manufacturer. By the end of the year, the site will boast four production lines.

### Everything under one roof

There is more to Neuffen than just its proximity to ElringKlinger's headquarters. The scale of the site is another obvious benefit, providing the basis for highly effective operations. All the key departments associated with electric drive units and battery technology are located in Neuffen. It is home to development, quality and project management, and product and manufacturing engineering – with short lines of communication guaranteed. It goes without saying that Jürgen Weingärtner's office is also located here; like many other staff members, he has a view of the imposing site known as the birthplace of the state of Baden-Württemberg, the ruins of Hohenneuffen Castle.

At its Neuffen site, ElringKlinger is fully focused on developing pioneering solutions tailored to the world of mobility – present and future. Dedicated testing

and validation facilities, such as cell, module, and system tests or component validation, are available for the purpose of assessing the various products in their entirety. From development to prototyping, testing, and series production – everything comes together at the site specializing in the technologies of the future. From individual components – such as cell contacting systems, housings, and covers – to complete battery systems. Short development cycles, the complex interaction of individual components and exacting standards with regard to cost-effectiveness and sustainability call for an integrated approach, as Jürgen Weingärtner emphasizes. This is an essential prerequisite for creating intelligent solutions at the highest technological level.

### Extensive testing options

The testing department at the Neuffen site has a special role to play, as ElringKlinger relies primarily on in-house expertise to assure the quality of battery development. Test capacities relating to battery storage and module, cell, and component evaluation at the site for emerging technologies were expanded once again to ensure the continuous expansion of ElringKlinger's e-mobility portfolio. Alongside high-tech devices for analytical purposes, such as GloveBox, X-ray, and scanning electron microscopes, the Neuffen facility can rely on shakers, hardware-in-the-loop systems, and test benches for cells and battery systems of various designs.

As Jürgen Weingärtner explains, ElringKlinger currently tests and validates battery systems, modules, cells, and components over an area of 2,000 square meters at its Neuffen site. The spectrum of expertise ranges from mechanical tests to electrical and electrochemical





Among other products, the plant in Neuffen manufactures cell contacting systems.

**» The Neuffen site is ideally suited to evolving our battery technology products in an effort to retain our strong position in the future. «**

Jürgen Weingärtner, Senior Vice President Electric Drive and Battery Technology, ElringKlinger

tests. The site's testing capabilities cover methods to ensure that all relevant test specifications and standards are met.

Covering an area of over 1,500 square meters, the prototyping facility is where new technologies, processes, and products are put into practice. It is here that the foundations are laid for successful industrialization and series production, as Weingärtner well knows. The various products are manufactured here in close coordination with the development departments.

The flexible operating lines at the Neuffen plant are designed to ensure product-oriented manufacturing, assembly, and testing, from individual prototypes to small-batch production. Processes such as laser welding, ultrasonic welding, bonding, and many more besides are adapted to the requirements of battery storage systems, battery modules, cell contacting systems, and cell covers. At the end of the process chain, the prototypes and small-batch parts then undergo full end-of-line testing.



Various products from the Electric Drive and Battery Technology business unit have been installed in a demonstration vehicle.

# 1,500 m<sup>2</sup>

Covering an area of over 1,500 square meters, the prototyping facility is where new technologies, processes, and products are put into practice.

## Cell contacting system as a key to success

The cell contacting system, which was used in the BMW Group's first all-electric vehicle, the BMW i3, is one of the first products developed and manufactured by ElringKlinger in the field of battery technology. ElringKlinger cell contacting systems for lithium-ion batteries in various configurations are tailored precisely to customer requirements; they can be fitted directly onto the cell combination and welded together accordingly. Cell contacting systems consist of a plastic carrier frame that accommodates the cell connectors and ensures installability in all tolerance positions. The required voltage and temperature sensors are already built into the systems. In addition, the monitoring electronics (CSC) can also be integrated. Automotive plug systems or screw connectors can be used for the electrical connection to external units.

This component is a major success factor in ElringKlinger's overall battery strategy. It is destined to find its way from the Neuffen plant to end customers.



Cell contacting systems are responsible for conducting the current and monitoring the voltage and temperature.



## FORWARD- LOOKING BUSINESS

ElringKlinger has been mass-producing battery components for more than a decade. The company puts its expertise in metal forming and punching technology to good use in the production of cell contacting systems. The development and production process for cell contacting systems is based on the company's core capabilities, and it is precisely this aspect that allows ElringKlinger to achieve a high proportion of value creation within the Group itself.



### CELL CONTACTING SYSTEMS FOR THE NEW

#### CLASS OF THE BMW GROUP

ElringKlinger has been awarded a high-volume series production contract by the BMW Group, covering a period of several years. At the Neuffen site, the company produces the latest generation of cell contacting systems for the Neue Klasse series to be launched by the Munich-based manufacturer of premium vehicles. The European start of production (SOP) for this order is scheduled for 2025. This is to be followed by production and delivery for the Asian market.

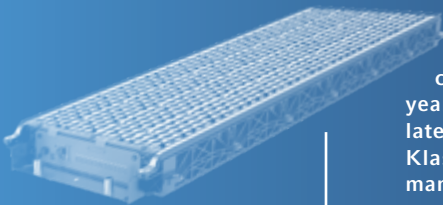

### MAJOR ORDER FOR BATTERY COMPONENTS

ElringKlinger has received an additional series production order for cell contacting systems from a global battery manufacturer for the series platform of a German premium carmaker, with a total volume in the mid-triple-digit million euro range and a contractual term of around nine years. Production at the Neuffen site for technologies of the future commenced in 2023. This order is also considered an important step for ElringKlinger as it pursues its transformation; it bears testimony to the Group's expertise as a premier supplier of battery components.

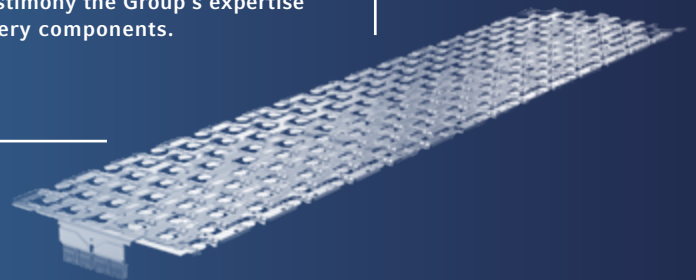

» ElringKlinger cell contacting systems are tailored precisely to customer requirements; they can be fitted directly onto the cell combination and welded together accordingly. «



# GREEN



Under construction: Hydrogen tanks will increasingly become part of our industrial landscape in the future. ElringKlinger is developing fuel cell components for the production of green hydrogen by means of PEM electrolysis.

# AHEAD

# STEAM

As a Group, we are unleashing our strengths in an effort to drive fuel cell technology forward and help shape the future, the aim being to reach the pinnacle of ElringKlinger's aspirations: to play our part in achieving carbon-neutral and climate-friendly mobility for society and the planet as a whole. The Group drives this success by innovatory prowess, creativity, and a measured approach to risk.

Serial product #1

## NM5-EVO

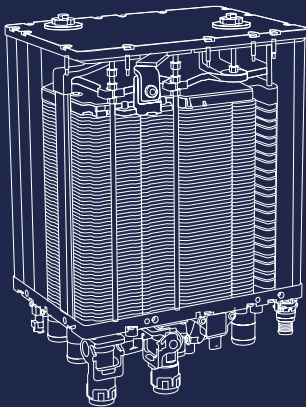

The highly scalable and compact platform with 71 to 335 cells and a power rating of up to 76 kW<sub>el</sub> can be deployed, among other things, as a range extender for cars and light commercial vehicles in the automotive sector or for intralogistics applications such as forklift trucks.

Our company's expertise is built on many years of experience in the development and research of fuel cell technology, representing a trump card that provides access to a wide range of hydrogen-based applications. Within the ElringKlinger Group, all of this expertise has been brought together at EKPO Fuel Cell Technologies GmbH (EKPO for short), a joint venture between ElringKlinger and the French supplier Plastic Omnium – based at the Group's headquarters in Dettingen/Erms. EKPO develops and produces fuel cell systems and components for various applications. One of the company's core products is the fuel cell stack. It is the "power plant" capable of generating energy by means of a chemical reaction, in our case of hydrogen and oxygen. At present, EKPO deploys systems that enable highly automated production to automotive standards of up to 10,000 stacks per year. What is more, its operations cover the entire process chain – from pre-assembly, stack assembly, and stack compression to final assembly and full end-of-line testing. Building on this set-up, the high-tech subsidiary can look forward to an exciting journey as it moves forward. To highlight our achievements and next-generation developments, we have selected three of the new orders placed with the company over the course of the 2023 financial year, the specific details and features of which are presented below.

### The Classic

When it comes to complete fuel cell stacks, the emphasis is on individual compactness and high power density. For ElringKlinger, as an established development partner to automobile manufacturers, it is one of those "classic situations":

a carmaker places parallel development orders with the supplier, in this case EKPO, at an early stage. This means that our engineers and the customer's engineers, as a supply-side team, work together as partners and in close cooperation during the development stage of the future vehicle. The fact that EKPO is awarded such contracts on so many occasions is also a testament to the outstanding performance features of its stacks: compact and customized stack design combining high power density and best-in-class quality. One of the orders for such stacks required a combination of a customized bipolar plate, which is a key component within the cell stack, and a matching high-performance MEA<sup>1</sup> to achieve the specified performance targets. This is quite a challenge, especially when it comes to small installation footprints.

### The Ultrafine

The metallic bipolar plate – less than 1 mm thin and featuring ultrafine, micrometer-precise channel structures in extremely thin layers of sheet metal – has many parallels to a cylinder-head gasket in terms of process engineering. As regards complexity, both products appear to be relatively simple at first glance, but require high-precision punching, forming, and embossing. While the focus of the cylinder head gasket is on reliable and permanent sealing, the bipolar plate within the fuel cell stack has the task of supplying and distributing the hydrogen, atmospheric oxygen, and coolant. The gases react on catalytically active layers to form water and provide the electrical power.

Alongside R&D know-how, when it comes to the actual design, large-scale production also requires high-end industrialization expertise with regard to tooling, coating, treatment, and metal forming – based on an inter-linked manufacturing process. Drawing on these core competencies, EKPO came out on top last year.

### The New

A step back into the upstream value chain marks a decisive step forward for the Group in strategic terms. This is an apt description of EKPO's entry into the promising electrolysis market. EKPO is currently developing next-generation components as part of a cooperation agreement concluded in 2023 with H-TEC SYSTEMS, a specialist in PEM<sup>2</sup> electrolyzers and electrolysis stacks. PEM electrolysis exhibits better cold-start properties than so-called AEL electrolysis. The joint ambition is to establish a greenhouse-gas-free process for the

production of green hydrogen. In contrast to the gray or blue hydrogen currently in use, this hydrogen is produced with the help of renewable forms of energy. This is used to power the electrolyzer, which splits water into hydrogen and oxygen. When it comes to establishing green hydrogen production and decarbonizing various industrial sectors in the future, the focus is on electrolysis stacks in the megawatt range. Speed was of the essence as part of this project, which is why EKPO, with its proven expertise in metallic bipolar plates and its existing infrastructure, is the perfect partner for large-scale production.

### Green steam ahead

In its efforts to develop a new generation of stacks, EKPO is focusing on a solution for heavy-duty transportation. When compared to batteries, fuel cells are of particular interest to this sector due to their greater range, faster refueling options, and weight advantages. In 2023, EKPO received approval for federal and state funding of up to EUR 177 million as part of the European "IPCEI Hydrogen" program, the aim being to develop a new generation of stacks for this

Serial product #2

## NM12 SINGLE

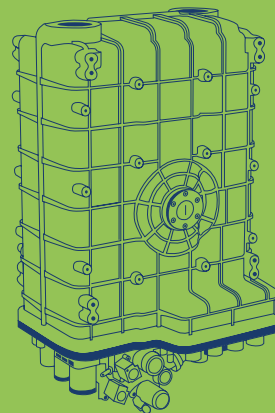

With its 359 cells and a power rating of 123 kWel, the NM12 Single stack is the perfect choice for a wide range of high-performance mobility applications.



<sup>1</sup> Together with the bipolar plate, the membrane electrode assembly (MEA) represents an important component of the cell units arranged in the stack.

<sup>2</sup> PEM technology (PEM: polymer electrolyte membrane) excels above all when it comes to reactions at relatively low temperatures, which is why it is also referred to as a low-temperature fuel cell.

## The spectrum of future applications for hydrogen-based, and thus climate-friendly, technologies is broad.



high-performance segment of the market in particular. The funds also form an integral part of the German government's national hydrogen strategy and will be allocated by the Federal Ministry for Digital and Transport and the Baden-Württemberg Ministry of the Environment in the years up to and including 2027. In addition, the company's efforts in pursuit of its chosen path are underpinned by its involvement in various funding projects (e.g., HyFab, Ulm, BEST4Hy, EU, etc.) and the roll-out of activities at Group sites in North America and China. The spectrum of future applications for hydrogen-based, and thus climate-friendly, technologies is broad. This, too, forms part of ElringKlinger's mission!

Serial product #3

### NM12 TWIN

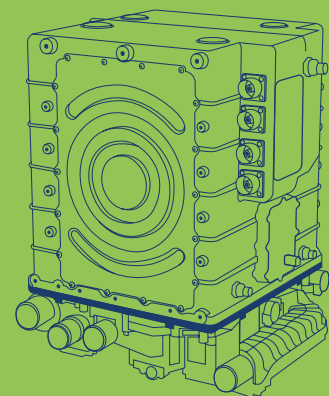

The powerful Twin module has two sets of 299 cells and a power rating of 205 kWel. It excels above all in the heavy-duty, rail, and marine sectors.

# THE BIG



# PICTURE

**The issues driving the world are the issues driving ElringKlinger: the advancement of mobility and sustainability in all its dimensions. Conservation of resources, climate change mitigation, safety, convenience, and efficiency are at the top of the agenda. We were quick off the mark in charting the right course for the future and are committed to evolving every aspect of our core competencies as we move forward. This also applies in particular to those business units whose origins lie in the field of conventional mobility. As a system partner to our customers, we always look at the big picture and are keen to play an active role in the process of transformation within the automotive industry – and beyond.**

## **PIONEERING SOLUTIONS**

**ElringKlinger's activities relating to battery technology, fuel cells, and electric drive units (EDU) are consolidated within the E-Mobility unit. At the same time, the business units that had their origins in the field of conventional mobility, i.e., diesel and petrol vehicles, are also well equipped for current and future challenges: Metal Sealing Systems & Drivetrain Components, Metal Forming & Assembly Technology, and Lightweighting/Elastomer Technology.**

Bridging distances, pursuing an active social and cultural life, transporting goods, advancing the economy and prosperity, broadening horizons – activities that would be inconceivable without mobility. At the same time, using resources in such a way that current and future generations are not compromised with regard to their opportunities and quality of life is considered equally important. Economic efficiency, social justice, ethical principles, and ecological viability – these are the maxims guiding sustainable endeavors. At ElringKlinger, the issue of mobility and sustainability permeates all corporate and business units. At company level, this includes environmentally friendly production processes, a certified environmental management system, the objective of achieving global carbon neutrality in net terms by 2030, strong employee retention, and social commitment. At product level, sustainable mobility is firmly enshrined in the activities of all business units, as our portfolio contributes to the reduction of pollutant emissions and the ongoing refinement of environmentally friendly mobility concepts.

### **Expertise meets business fields of the future**

ElringKlinger supplies key components and systems tailored to present and future forms of mobility. Our aspiration: instead of being content with the standards we have achieved, we are committed to leveraging our unique expertise for the purpose of accelerating electromobility and further optimizing combustion-engine vehicles during the phase of transition. Our aim remains to help reduce or avoid fuel consumption and emissions.

The carrier structure of our lightweight cockpit cross-car beam accommodates the instrument panel, steering column, heating and ventilation modules, airbags, and other components and connects them securely to the body.



ElringKlinger-engineered ElroForm™ battery covers are safe, lightweight, durable, and economical.



Pressure equalizing unit with a PTFE diaphragm produced by ElringKlinger Kunststofftechnik: simple press-fitting and reliable venting are achieved with customer-specific design solutions.



Our MetaloBond™ rotor/stator laminated stacks are renowned, among other things, for their high inter-layer sealing performance. This provides the basis for customer concepts centered around directly cooled electric motors.

In addition, numerous products developed by ElringKlinger can be used in areas of application in which the type of drive system is of no relevance, such as PMH structural components (polymer-metal hybrids), crash elements, brake covers, underbody shields, or dynamic drive components such as rotor/stator laminated stacks, or planetary and disk carriers. When it comes to our customers, we are trailblazers and trusted partners from the initial idea to the finished product. Our core competencies in high-precision metalworking (punching, embossing, forming, and coating), plastic injection molding, processing of high-performance plastics, and tool-making form the basis for these activities. This is complemented by our unique materials expertise and our ability to reliably combine a large number of different components within a single assembly.

#### Transformation of the “traditional” business units

We would now like to take a closer look at how the change toward electromobility and new drive concepts is unfolding or has unfolded. The Metal Sealing Systems & Drivetrain Components unit (formerly Cylinder-head and Specialty Gaskets) offers customized sealing systems for a wide range of applications. Both materials and design are tailored perfectly to the specific requirements; additional functions can also be integrated. The advantages: fewer individual parts, less assembly work, weight reduction, cost streamlining, and optimized functionality. We are also able to unleash these strengths when it comes to e-mobility applications. For example, our MetaloSeal™ metal-bead gaskets ensure optimum EMC shielding in battery systems or electric drive units (EMC: electromagnetic compatibility). TopSeal™ housing parts combine cover and seal in a single functional unit and are used, for instance, as battery module covers or as service covers in electric drive units and fuel cell stack modules. Electric drive units feature various dynamic drive components from ElringKlinger, such as MetaloBond™



## For us, system excellence is all about being a pioneer, creating greater scope for action, and achieving goals faster. We contribute to sustainable mobility by providing high-performance product solutions.

rotor/stator laminated stacks, in which full-surface bonding of the layers ensures an optimum sealing function; this provides the basis for directly cooled e-machine concepts. Among the dynamic components are also our brake disk carriers for high-performance brakes, which offer high functional reliability, low weight, and optimum mechanical stability. They can be used in both combustion and electric vehicles, i. e., regardless of the type of drive.

Within the Metal Forming & Assembly Technology unit (previously Shielding Technology), our ElroShield™ thermal and acoustic shielding systems are still in demand. Having said that, more than 50% of the total nomination volume in the 2023 financial year was actually attributable to components for battery-powered electric vehicles. The portfolio includes ElroForm™ product solutions that are used wherever crash safety, lightweight construction, cost-effectiveness, and thermal, acoustic, and EMC shielding are of particular importance. Among these, in particular, are xEV applications, such as battery housings or assemblies, as well as components for the EDU and also in the body-in-white environment (“body in white” refers to the bodyshell before painting, etc.). In developing the ElroForm™ Ultra product group, ElringKlinger has succeeded in creating lightweight metal components with significantly improved forming properties. The weight of these components is comparable to that of lightweight aluminum components. Until now, however, the design could only have been achieved with the help of steel, a much heavier material. Our portfolio also includes ElroShield™ EV battery shields, which make an important contribution to occupant safety in the event of a thermal runaway of the battery, for example. Here, too, flexibility makes all the difference: they can be integrated into customer products not only at system level but also at module and cell level.

Lightweight construction, one of the key technologies within the automotive industry, has a long tradition at ElringKlinger: the foundations for today’s Lightweighting/Elastomer Technology unit were laid back in the late 1990s. At the time, our very first plastic cam cover modules went into series production. Today, we supply customized structural components made of solid plastic, in combination with metal or in composite-hybrid design for a wide range of primarily drive-independent applications throughout the vehicle, such as cockpit cross-car beams, front-end carriers, door modules, underbody shields, or engine mounts. In this context, the focus is always on weight reduction, functional integration and optimization, performance, robustness, and efficiency. We also apply our expertise specifically to applications in the field of battery systems, fuel cells, and drives. One of the highlights is our laser-welded plastic housing for the ElringKlinger performance battery module. As part of this solution, which was developed in-house, the innovative immersion cooling concept enables a high electrical output – without any reduction in power while driving or charging. Other product solutions in the field of e-mobility include ElroSafe™ underbody shielding. In addition to providing excellent protection for the battery, which includes road-related impact protection, this system boasts high thermal resistance with regard to thermal propagation and can also be equipped with EMC shielding. Thus, ElroSafe™ can be deployed directly as part of the battery housing – performing all the necessary functions. Another key benefit: ElroSafe™ is fully recyclable. The business unit’s portfolio also includes elastomer and metal-elastomer sealing systems adapted for use in numerous applications.

Our subsidiary ElringKlinger Kunststofftechnik GmbH (EKT) specializes in gaskets, engineered parts, assemblies, and modules made of high-performance plastics, which are used in a wide range of industries, including medical technology, mechanical engineering, chemical and process technology, and the automotive industry. EKT is also taking advantage of the opportunities presented by the technological transition toward electromobility. For example, in the form of sealing components for electric drive systems exposed to high pressures and speeds, extreme temperatures and dry running,

or insufficient lubrication, such as ElroSeal™ E rotary shaft seals. Valve seals for the cooling and air conditioning circuit are acknowledged for their superb performance in the field of thermal management.

### **E-Mobility unit continues to pick up speed**

The battery and the fuel cell are key technologies when it comes to the electrification of the powertrain. ElringKlinger can draw on extensive experience in both areas – in terms of development, industrialization, and series production. Together with hofer powertrain, we are also an acknowledged specialist for electric drive units.

As far as battery technology is concerned, we operate as a full-service supplier of battery components for the series- and mass-production market as well as modules and systems for niche markets with special requirements, e.g., the sports car segment, and for stationary applications. Building on our experience from numerous series-production projects, we have already established ourselves as one of the leading suppliers of cell contacting systems in Europe. For detailed information on our activities in the battery sector, please refer to page 20 ff. Our joint-venture subsidiary EKPO Fuel Cell Technologies is a premier full-service supplier of fuel cell stack modules and components. In addition to supplying standardized products, we are capable of developing customized solutions for every level of integration. With a choice of three stack platforms (NM12 Twin, NM12 Single, NM5-EVO), we cover the output range from 16 to 205 kWel. We are also acknowledged for the highest power density within the market. For further information on EKPO, please refer to page 26 ff. Under the hofer powertrain products brand (hpp), ElringKlinger and hofer powertrain are committed to engineering highly efficient electric drive units on the basis of a joint venture. Our customers benefit from tailor-made solutions: niche or series application, complete system or the integration of individual modules, standard system or customized configuration. Alongside e-motor, transmission, and power electronics, the portfolio also includes control software, thermal management, and safety concepts.

### **Sustainability has many dimensions**

Mobility is by no means limited to cars and trucks; ElringKlinger products also excel in other fields of sustainable mobility thanks to their performance, top

**Our customers benefit from ElringKlinger's combined materials, engineering, and manufacturing expertise. Thinking ahead, developing solutions, breaking new ground, taking responsibility. It is these qualities that set us apart – with a pedigree spanning more than 140 years.**

quality, and efficiency. EKPO's PEMFC stack modules can be used in the off-highway, rail, and marine sectors; the most recent contracts cover the supply of NM12 single stacks for a cruise ship. The aviation sector also offers promising potential when it comes to future applications. As part of our strategic partnership with the Airbus Group, fuel cell technology is to be further refined and validated in this specific area.

Our battery modules and components can also be deployed in a wide range of applications, e.g., in industrial trucks, municipal vehicles, light electric vehicles, e-bikes, and cargo bikes. Speaking of e-bikes: they require safe, reliable, and easy-to-install seals, such as the customized MetaloSeal™ housing gaskets developed by ElringKlinger for e-bike drives.

As a guiding principle, our commitment to sustainability is also reflected in applications for power generation and storage as well as various other industrial solutions. Our battery and fuel cell technology, for example, can be used in stationary energy storage and generation systems as well as in mobile and stationary charging stations. Another point of interest: our subsidiary ElringKlinger Kunststofftechnik offers a highly efficient, environmentally friendly water heat exchanger, ThermoGenius™ Water, for heating or cooling individual buildings and entire blocks of buildings located close to water. The innovative solar panels developed by US

start-up Solar Roadways are all about environmentally friendly power generation on roads and sidewalks as well as at airports and the like; ElringKlinger was commissioned to assemble the panels.

Last but not least, we are embracing the opportunities presented by the rapidly growing electrolysis market, as the production of green hydrogen is considered a key element of the "energy transition." EKPO Fuel Cell Technologies has transferred its many years of experience in the fuel cell sector to electrolyzers and is acknowledged for its robust, durable, and cost-effective metallic bipolar plates. Our Lightweighting/Elastomer Technology unit ensures reliable, best-in-class sealing with sealing systems that can also be applied to bipolar plates, for example. Good to know: the elastomer materials used are developed by ElringKlinger itself. ElringKlinger Kunststofftechnik GmbH is a perfect partner when it comes to scaling electrolyzers; its portfolio includes, for example, seals with a diameter of up to three meters as well as hoses and pipes made of fluoropolymers.

In the face of challenges, we are spurred on to deliver our ultimate performance. Working in close collaboration with our customers, we are committed to playing our part in the transformation of the automotive industry and the energy transition, as we strive each and every day to push back the boundaries of what is considered possible.



EKPO's NM12 Twin PEMFC stack module was developed for applications with high power requirements (>150 kW), especially for heavy-duty transportation. Other possible areas of application include the rail and marine sectors.



Under the hofer powertrain products brand, we offer a range of electric drive units for the high-performance niche market, such as the High Compact Torque Vectoring EDU. These systems deliver outputs of up to 350 kW in single-system applications and up to 600 kW in torque vectoring systems. Optional extras include multispeed transmission and disconnect clutches, direct cooling, booster function, and many other features.

Our performance battery module consisting of cylindrical lithium-ion cells is packed with a wealth of technological expertise that is applied to customer-specific development projects. Key performance features:

- Connection in series possible up to an integrated system voltage of 1,000 V
- Immersion cooling enables high electrical output without power reduction while driving and charging
- Battery housings and plastic modules in a highly integrated lightweight design
- wireless battery management system (cable-based solution possible on request)
- flexible system configuration thanks to individual modules or module-to-chassis battery design
- very low overall height enables a low seating position

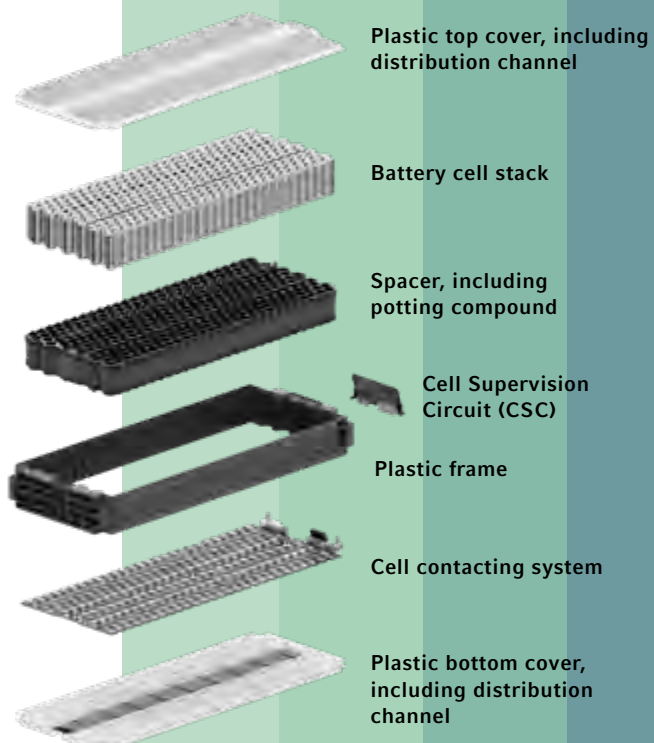

Plastic top cover, including distribution channel

Battery cell stack

Spacer, including potting compound

Cell Supervision Circuit (CSC)

Plastic frame

Cell contacting system

Plastic bottom cover, including distribution channel

# THAT'S THE SPIRIT

Initially, a strategy tends to be abstract. It becomes more tangible when employees put it into practice on a daily basis. In the context of its SHAPE30 strategy, the Group has identified corporate culture as one of five success factors underpinning the process of transformation. Trust and reliability, passion and team spirit, integrity, sustainability, innovation, and focus are among the core values that guide ElringKlinger employees in their day-to-day endeavors ...

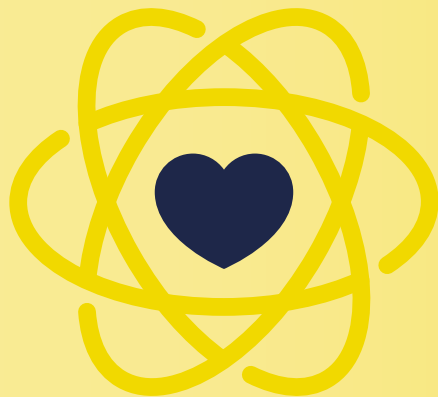

## 3 QUESTIONS FOR ...

# 1

### Which aspect of sustainability do you consider most important?

Sustainability starts with people: in a culture in which progressive thinking is encouraged and new ideas are given space, sustainable solutions can flourish. It is also important that sustainability is firmly anchored in the organizational structure and that there are concrete responsibilities, processes and goals that are pursued and reflected upon.

### Why is it important for you to be able to develop personally at work?

For me, being able to develop at work means approaching every task with self-confidence, getting to know your strengths and weaknesses, and dealing with them. It is important to approach topics with an open mind: By acquiring new skills and further developing existing skills, you help the company and yourself as a person to progress.

# 2



# 3

### What does it mean to you when you and your colleagues can rely on each other?

Trust and reliability are essential for a good working atmosphere. At the same time, it is the basis for successful collaboration and ultimately for the success of a company: what is more unifying than working towards a common goal? In my opinion, it is important to treat each other with respect and to support each other at work. In an environment of trust, we are honest with each other, can exchange different opinions and admit mistakes.

## ANJA JI

**Department:** ElringKlinger Engineered Plastics (Qingdao) Co., Ltd.

**Position:** HR Manager

**With the company for:** 7 years

**ElringKlinger in three key words:** partner for a sustainable future, globally present, customer-oriented

## 1

**Why wouldn't you be willing to give up your team for anything in the world?**

After so many years of working together as a team, we understand each other without having to say anything. We support each other with problems and seek solutions in a joint effort. I wouldn't be without my team under any circumstances, as we are there for each other and can rely on one another. But we also have fun and laugh together from time to time. In my opinion, humor should never be neglected in our daily interactions.

## 3

**To what extent do you take responsibility as part of your daily work?**

Taking responsibility is simply part of my job: I make decisions every day as to whether the product in question is good and can therefore be dispatched to the customer. This applies to day-to-day work in production as well as to product audits.

**What encourages you to give 100 percent in your work?**

When I implement something, I always do my best. I don't need any external incentive or encouragement to do so. This is my own sense of motivation. But of course I'm pleased when I receive positive feedback for my work. Recognition encourages you to do the right thing and shows that you are valued.

## 2

**SEVGI AKBULUT**

**Department:** Manufacturing Assembly

**Position:** Production Employee

**With the company for:** 25 years

**ElringKlinger in three key words:** ambitious, responsible, home

## How do you come up with new solutions at a professional level and what inspires you?

1

Real-time solutions for this evolving business often still tie to core values. My experience in the Automotive industry first as an end customer and entrepreneur, then through multi-level distribution in wholesale and retail allows me to view through the customer's eyes. Finding solutions that are right for the customer as well as our organization inspires me.

## What excites you about ElringKlinger?

Working for a 140 plus year old organization that stays cutting-edge and innovative. A company where quality or customer experience is never compromised. Firmly rooted in its history and core competences and using that knowledge and experience to help build a sustainable future. I am excited to be part of that bridge – from the traditional aftermarket to what will become our future reality.

2



## RONALD DUPONTE

**Department:** ElringKlinger Automotive Manufacturing, Inc./US

**Position:** Sales Manager North America

**With the company for:** 2 years

**ElringKlinger in three key words:** quality, innovation, environmental consciousness

## How do you always stay focused in your line of work?

Putting myself in the customers' shoes. Their experience and finding solutions to their issues are my number one priority. There are many suppliers in our industry and people must make buying decisions. I still believe that people buy preferably from people – people they like and trust. My goal is not to give them a reason to look anywhere else.

3

CH

N

AI

RE

AC

TI

ON





**The transformation of the automotive industry toward zero-emission mobility means much more than simply fitting a fuel cell, electric motor, or battery instead of a combustion engine and fuel tank. “Transformation” here means real change, not just further down the line when the vehicles are on the road but upstream too – all the way along supply chains. The crises of recent years have made it clear that companies with global operations need to be proactive in shifting their supply chains toward more sustainability and resilience. Among other things, this calls for greater supply chain transparency in order to meet the challenges posed by the new (drive) technologies.**



Via its innovative cell cover, ElringKlinger is part of a large-scale international project (IPCEI “EuBatIn”) to build a value chain for the European battery industry.

Rather than simply changing the technology used inside the products, electromobility is radically transforming the entire industry. This is making the supply chain a key part of the automotive industry because it too is undergoing change – in terms of both the manufacture of components, modules, and systems for electric vehicles and the continued refinement of a sustainable, resilient, and transparent supply chain.

Supply chains are complex by their very nature, with many goods and components being obtained from one country and then used in the manufacturing process in another. Some machinery and systems as well as production tools are purchased and made at sites all over the world before finding their way into ElringKlinger’s global manufacturing network. With sustainability along the entire value chain being a high priority for ElringKlinger, the company has set itself the ambitious target of making its in-house global production carbon-neutral by 2030 as a first step.

# 60

**The ElringKlinger Group has suppliers in over 60 countries that operate in more than 40 sectors.**

**In a world in flux, supplier relationships built on partnership can lay the foundations for resilient supply chains. However, this requires both trust and transparency along the entire chain.**

# 2030

**ElringKlinger has set itself the target of making its in-house global production carbon-neutral by 2030.**

Over the past few years, unforeseeable incidents such as the container ship stuck in the Suez Canal, container backlogs at ports caused by the COVID-19 pandemic, and various armed conflicts have demonstrated just how fragile supply chains can be. Yet they also find themselves buffeted by other external factors such as extreme weather events, volatile energy prices, and import restrictions – all challenges that call for maximum flexibility to keep supply chains stable and prevent assembly lines from grinding to a halt.

At the same time, supply structures – and thus also their complexity – are evolving, driven by the ongoing transformation toward electromobility. This is because new products, such as battery systems and electric drive unit components, are bringing a new wave of suppliers onto the scene, and these new components and their suppliers have to be integrated seamlessly into existing supply chains.

The high degree of complexity in supply chains thus requires greater transparency because not all goods are available locally. Thus it is all the more important that raw materials are mined and processed in an environmentally sustainable way and that they can be traced right back to their origin. And the same applies to upholding compliance standards. By way of a “chain reaction,” therefore, ElringKlinger expects high standards of its suppliers, who in turn enforce them on their own suppliers. This is ensured with the help of ElringKlinger’s supplier code of conduct, which covers areas including environmental responsibility and compliance with social standards, the law, and the principles of business ethics. With it, the ElringKlinger Group commits its suppliers to taking corrective action in the event of a suspected or actual breach of human rights or environmental law because fulfilling one’s due diligence obligations throughout the supply chain is extremely important to ElringKlinger on account of its strong corporate culture.

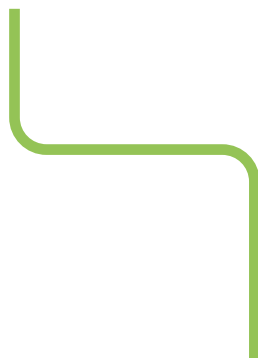

To identify suppliers that may potentially harbor risks, ElringKlinger uses the results of a risk analysis that gives it the underlying data it needs for preventive countermeasures. In addition, an innovative software tool will help in future to reach out to suppliers directly and obtain data on additional issues raised by the risk analysis, thus contributing to greater transparency along the supply chain.

ElringKlinger has also set up anonymous whistleblower systems that anyone can use to report misconduct; the company requires its suppliers, staff, and subcontractors to raise awareness of these systems. Taken together, these measures are fostering a culture of integrity and transparency throughout the supply chain that is underpinning long-term partnerships and sustainable growth.

The automotive industry's transformation toward electromobility has a societal and environmental dimension as well as a technological one, and ElringKlinger is playing an active role in helping to shape a responsible future for the industry through critical reflection and continuous improvement. Besides being something to aim for, a sustainable, resilient, and transparent supply chain is also ElringKlinger's top priority for its strategic sustainability management.

# 14

**The supplier code of conduct  
is available in 14 languages.**

**Model construction for  
electric drive units:  
creating the stator for  
an electric motor.**





# COMPASSION WITH CONVICTION

**Being a manager entails much more than simply being a good boss. It is about taking responsibility for the company and for society as a whole. At ElringKlinger, a progressive corporate culture goes hand in hand with a culture of responsible leadership. Social responsibility has always formed an integral part of ElringKlinger's DNA. Indeed, it has been actively practiced since the company's inception.**

The history of ElringKlinger AG can be traced back to Paul Lechler. Together with his father, the company's original founder decided as early as 1875 to donate to charity 10% of the profits generated by what was then a family business. Paul Lechler supported various social projects throughout his life. In 1916, for example, he had a convalescent home for tropical diseases built in Tübingen, a hospital known today as the "Paul-Lechler-Krankenhaus". In 1928, Paul Lechler set up a trust and stipulated in his will that its charitable work should be continued after his death. This tradition has been fully embraced ever since – through the work of the aforementioned trust. Its efforts are underpinned to a large extent by ElringKlinger's commercial success as a company. The Lechler Stiftung supports charitable projects in the fields of education and health, in addition to providing assistance for youngsters, the elderly, and the disabled. In 2008, the charitable trust introduced the Paul Lechler Award in recognition of innovative community projects in Baden-Württemberg.

At ElringKlinger, managers follow the example set by the company founder: social projects form an essential part of the HR development program for young professionals. The global "EKDrive High Potential Program" is dedicated to developing young talent for Group-wide management

and expert roles. Alongside an individual project, this 18-month management program also includes a social project. The participants come together according to region, conceive and present ideas for projects, and then put them into practice. The three teams currently assigned to this program have committed themselves to very different social projects – but their ambitions are always the same: they are passionate about their work and want to make a lasting contribution.

**» ElringKlinger is committed to a forward-looking management culture that not only produces excellent leaders but also focuses on its responsibilities to society as a whole.«**

Thomas Jessulat, CEO ElringKlinger



## GENERATIONS STAND TOGETHER

Housing and food insecurity, physical and mental health as well as age-appropriate housing – there are numerous challenges for elderly people in everyday life. Five colleagues from the USA, Canada and Mexico have launched the “EK Senior Living Program” to help seniors in need in their everyday lives. The idea came from a project member from Mexico, where many elderly people live in precarious circumstances. As part of the project, the team carries out various activities at ElringKlinger sites and works together with retirement homes and NGOs. In spring 2023, for example, the team entered a partnership with a long-term care home near Leamington, Canada. After a fundraising marathon, ElringKlinger employees visited the nursing home, built raised beds together with the staff and residents and planted herbs and vegetables there. In Toluca, Mexico, ElringKlinger employees collected donations and were able to sponsor a refrigerator and an armchair for the residents of a retirement home. The project team’s long-term goal is to set up a system in which ElringKlinger employees regularly support elderly people in their everyday lives.



## GIVING SILENCE A VOICE



With their project “DEAFPRIDE – Amplifying Silence”, nine colleagues from China, India and South Korea want to draw attention to the fact that deaf people have a voice in society. Affected children and young people need special educational support and often find it difficult to find a job after leaving school. The project team collects donations through various activities at ElringKlinger sites and outside the company to provide support in everyday life and educational opportunities. For example, handicrafts were sold at the Family Day in Changchun, a Christmas market was held in Qingdao and the team took part in the New Year event in Suzhou. In Pune, employees were informed about the project at a family day and High Tea event, while the team organized a coffee afternoon in Gumi-si. With the donations, the team supports partner schools for deaf children and equips a library, for example, or procures water filters for clean drinking water. Another sponsorship is with local bakeries where deaf people work. Cakes were ordered from the bakeries at the events – a huge success, and not only in terms of taste!

## LESS WASTE AND GREATER ENVIRON- MENTAL AWARENESS

Raising environmental awareness while making a positive contribution to the devastating effects of natural disasters: this is the aim of the “EK Clean-Up Days” launched by eleven colleagues from Germany, the UK, Turkey, and Spain. The objective of the events is to bring together as many employees as possible for one day and collect garbage in the vicinity of ElringKlinger plants. The Management Board donates a sum of money for every kilogram of garbage collected. The donations collected will benefit aid organizations supporting the victims of the earthquake that struck

Turkey in early 2023. The first EK Clean-Up Day took place in Bursa last November – 40 dedicated employees collected more than 1,200 kilograms of garbage in under four hours. This was followed by a leisurely get-together with refreshments. Further EK Clean-Up Days are scheduled for Reus, Dettingen, and Redcar in spring 2024. The initiative has also been well received at other company sites, such as Bietigheim-Bissingen. In the future, the project team can well imagine establishing Clean-Up Days as a regular event within the Group.

# Global Presence

45 SITES IN  
20 COUNTRIES

## NORTH AMERICA

**26.1%**

SHARE OF SALES

**1,701**

EMPLOYEES

**8**

SITES

## SOUTH AMERICA AND REST OF WORLD

**5.3%**

SHARE OF SALES

**456**

EMPLOYEES

**2**

SITES





**EUROPE**  
(EXCLUDING GERMANY)

**31.4 %**

SHARE OF SALES

**1,746**  
EMPLOYEES

**12**  
SITES



**GERMANY**

**19.8 %**

SHARE OF SALES

**4,074**  
EMPLOYEES

**12**  
SITES



**ASIA-  
PACIFIC**

**17.4 %**

SHARE OF SALES

**1,599**  
EMPLOYEES

**11**  
SITES



## IMPRINT

### **pulse**

The ElringKlinger AG Magazine  
Issue 2024

### **PUBLISHED BY**

ElringKlinger AG  
Max-Eyth-Straße 2  
D-72581 Dettingen/Erms  
Phone +49 7123 724 – 0  
www.elringklinger.com

### **EDITORIAL TEAM**

Dr. Jens Winter (V.i.S.d.P.),  
Petra Keppler-Matkovic, Heiderose Mall,  
Dr. Philipp Ottenstein, Judith Overbeck,  
Peter Renz

### **CONCEPT & DESIGN**

3st kommunikation, Mainz

### **PICTURE CREDITS**

ElringKlinger, EKPO Fuel Cell  
Technologies, GettyImages,  
Matthias Schmiedel, Midjourney/3st,  
Shutterstock

### **CONTACT (EDITORIAL TEAM)**

info@ir.elringklinger.com

### **PUBLICATION DETAILS**

“pulse” is published once a year together  
with ElringKlinger AG’s annual report.

The magazine’s content is protected by copyright.  
Reprints or the use of content – including excerpts –  
are prohibited without the prior written consent of  
the editorial team.

ElringKlinger basically uses a gender-sensitive form of  
language. For the purpose of readability, we have not used  
gender specific forms of grammar when referring to  
general designations of people. Specific terms relate to  
all people irrespective of gender.

ElringKlinger AG shall assume no liability for figures and  
statistics from third-party publications.



ElringKlinger AG  
Max-Eyth-Straße 2  
D-72581 Dettingen/Erms  
(Germany)

